

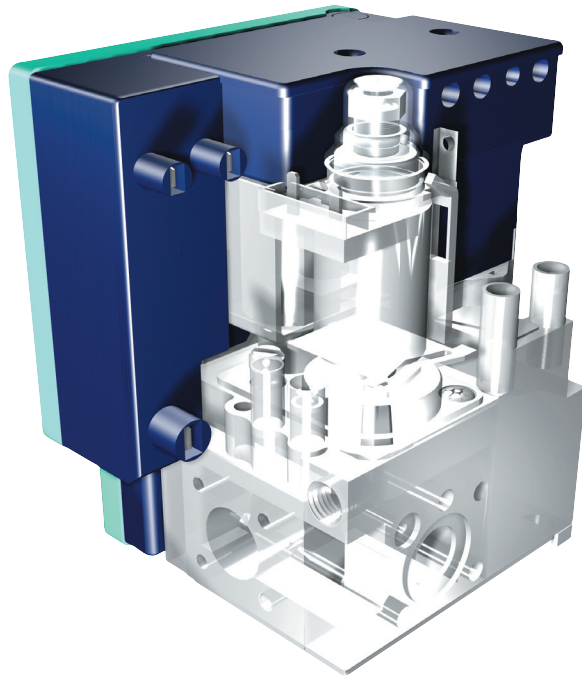

SITGroup

579 DBC



ELECTRONIC BURNER CONTROL DEVICE WITH MICROPROCESSOR FOR INTEGRAL MOUNTING ON SIT SIGMA MULTIFUNCTIONAL CONTROLS

Field of application

Home gas appliances such as boilers (with natural or forced draught including dynamic control of the air pressure switch), water heaters, hot air generators and gas radiators.

Main features

Gas burner ignition and control functions integrated and managed by digital technology (microprocessor).

Reference standards

EN 298 with reference to the "Gas Appliance Directive" (GAD 90/396/EEC).



579 DBC

DESCRIPTION AND APPLICATION

The 579 Digital Burner Control is a family of electronic devices with integrated functions for the safety and the control of combustion in home gas appliances and has the same functions of 537 ABC family, with which it is interchangeable.

The 579 DBC is dedicated in particular to boilers, water heaters and hot air generators with both natural draught and fan assisted burners.

All the functions are managed by a microprocessor and the product has obtained the certification of conformity with the most severe safety requirements.

The microprocessor structure combines the traditional features of reliability with high flexibility for the needs of the appliance and a wide range of possibilities for further customisation with adds-on such as timers, multiple attempts and so on.

The 579 DBC family of products has been specifically designed for fixing on SIT 840, 845 and 848 SIGMA multifunctional controls by means of an exclusive plastic box which integrates itself with the valve body and simplifies the connection of the solenoid valves.

Further customisation is easy to achieve thanks to the digital technology.

All the hardware and software architecture has been designed by SIT and innovative concepts and technologically advanced solutions have been implemented so as to enhance the device's reliability and performances.

BASIC FEATURES

- Compact design
- Direct assembly on the gas control
- Incorporated igniter with EMC filter
- Direct burner ignition (DBI) or by intermittent pilot (IP)
- Manual reset function and remote signalling of the non-volatile lockout state
- Multiple plug-in connectors
- Utilises well established electronic technology for high reliability of operations
- Precise and repeatable timings
- Multiple ignition attempts
- Flame detection by ionization
- CE approval according to EN 298:2003
- Repetition of the cycle after loss off flame during operation
- Permanent lock-out visualization, a without thermostat input being present
- Suitable for applications at wide ambient temperature range

Options available

- Fan and air pressure switch control
- Volatile lockout version for specific applications
- 230 V_{AC} flame presence signal
- Possibility to connect an automatic safety thermostat in series with the solenoid valve with manual lockout following its opening
- Protection degree IP40 or IP44
- Several pre-purge and safety timings can be tailored to the application.
- Different frequency of ignition
- Possibility of connection on phase-phase main supply power lines

579 DBC

OPERATION

Normal operation (natural draught or fan assisted)

During the waiting or purge time, T_w or T_p , the unit verifies that there is no parasitic flame signal present, and that the internal circuitry is operating correctly. If the unit is used on a fan-assisted application, the air pressure switch is verified to be in the N.C. (normally closed) or "no flow" position.

Upon powering the fan, the unit will not begin the operating sequence until the N.O. (normally open) or "flow" position is activated on the air pressure switch. After the scheduled waiting time T_w , or purge time T_p , the built-in igniter and the gas valve are energized. This commences the safety time, T_s . The ignition spark will ignite the gas and the flame will be sensed by the electrode.

If there is no flame the system repeats the ignition cycle, after a defined interpurge time, for a definite number of times and it goes definitively on lockout position in case there is no flame.

Upon sensing the flame, the HV spark will be suppressed and the gas valve will remain energized. When the thermostat is open, the valve and fan are de-energized and the control returns to the stand-by mode. The safety time of the 579 DBC has a constant duration in all operating conditions and, in particular, does not depend on the moment the pressure switch is switched over.

Resetting the unit

To reset the unit the reset switch is depressed for one second at least and then released.

WIRING DIAGRAM

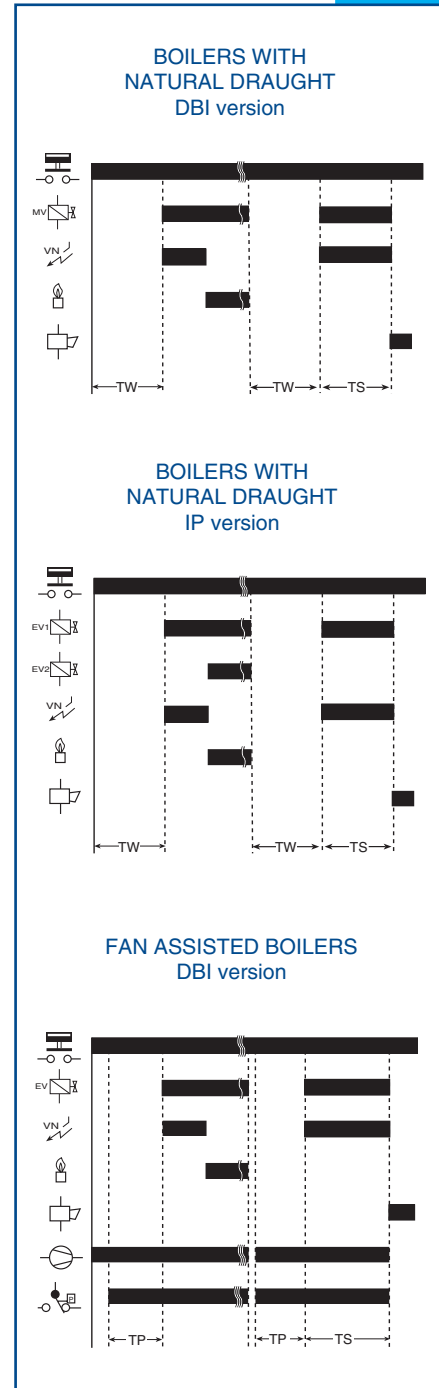
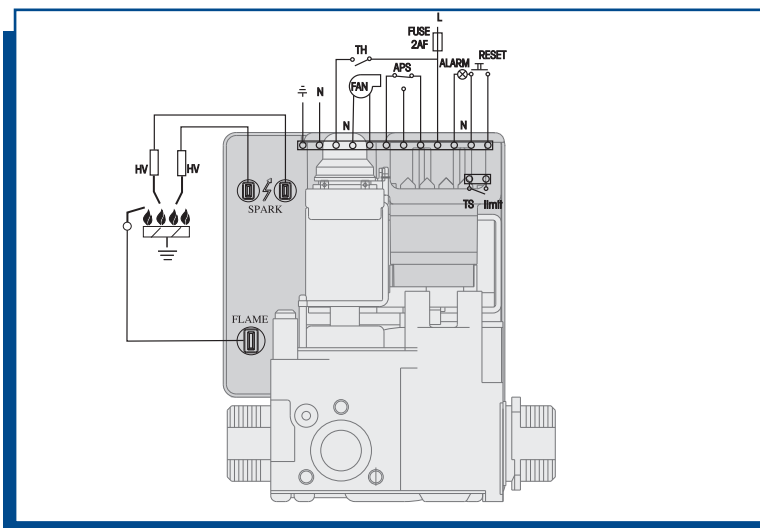



579 DBC

TECHNICAL DATA

AMBIENT WORKING TEMPERATURE

-20 °C to +60 °C

HUMIDITY

90 % max at 40 °C (not condensing)

SUPPLY VOLTAGE

230 Vac - 15 %, + 10 %, 50-60 Hz

POWER CONSUMPTION

12 VA

ELECTRICAL RATINGS

Gas valves: 230 Vac, 0.5 A, $\cos\phi \geq 0.4$

Fan: 230 Vac, 1 A, $\cos\phi \geq 0.6$

Alarm: 230 Vac, 1 A, $\cos\phi = 1$

230 Vac, 0.5 A, $\cos\phi \geq 0.6$

ELECTRICAL CONNECTIONS

High voltage probe: male fast-on connector 2.8 x 0.5 mm

Flame detection probe: male fast-on connector 4.8 x 0.8 mm

Other connections: male Molex series 2599 suitable for female Molex series 3001 and 3002 or compatible.

PROTECTION DEGREE

Standard IP 40

IP 44 with gaskets

TIMING

Minimum waiting time T_w or purge time T_p : 1 ... 240 sec.

Maximum safety time T_s : 3 ... 120 sec.

Ignition attempts 1 ... 10

Relative interpurge time 0 ... 240 sec.

FLAME SENSING

Minimum flame current: 0.9 μA

Recommended flame current: > 3 times the minimum current

FUSING

Internal: 2.5 A fast.

External: maximum 2 A fast or less depending on the electrical loads. This fuse protects the device in the event of overloading or short circuits and prevents the intervention of the internal fuse.

IGNITION

Ignition voltage: 15 KV at 30 pF load

Repetition rate: 25 Hz standard (4 ÷ 50 Hz)

Max. length of the cable: 1 m

Spark gap recommended: 2-4 mm

MOUNTING

Integrated on SIT SIGMA multifunctional gas controls.

DIMENSIONS- 579 DBC with 845 SIGMA VERSION G3/4 ISO 228

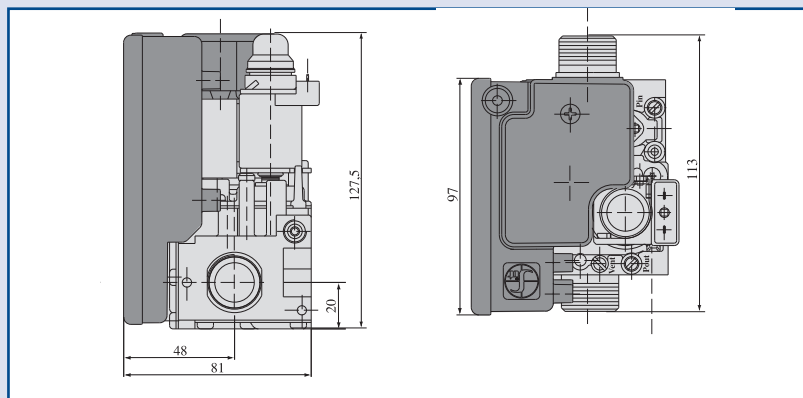

SITGroup

www.sitgroup.it - e-mail: mkt@sitgroup.it