



## PROFLAME2 IFC CONTROL BOARD

### USE AND INSTALLATION INSTRUCTIONS



Read the instructions before use.

## IMPORTANT

The Proflame2 Integrated Fireplace Control (IFC), is the flame ignition and control board part of the Proflame2 System which is available in three main configurations (BASIC/STANDARD/COMPLETE) for fan-assisted (FAN) and not fan-assisted (ATMO) appliance.

The BASIC System consists of the following elements:

1. Pilot assembly
2. Proflame Gas Valve 880, or 886 families of gas valves
3. Proflame2 Integrated Fireplace Control (IFC) Basic model
4. Wiring harnesses to connect gas valve, APS (FAN only), split flow and main/pilot burner switches
5. Fan burner and related air-pressure switch for fan-assisted

The STANDARD System consists of the following elements:

1. Pilot assembly
2. Proflame Gas Valve 885 family (also the 880, 886 families are compatible)
3. Proflame2 Integrated Fireplace Control (IFC) Standard model
4. Wiring harnesses to connect gas valve, APS (FAN only), split flow and main/pilot burner switches
5. Fan burner and related air-pressure switch for fan-assisted appliance
6. Proflame 2 TM\*S\*\* Series Transmitter
7. Optional system elements: split flow control valve

The COMPLETE System consists of the following elements:

1. Pilot assembly
2. Proflame Gas Valve 885 family (also the 880, 886 families are compatible)
3. Proflame2 Integrated Fireplace Control (IFC) Complete model
4. Wiring harnesses to connect gas valve, APS (FAN only), split flow and main/pilot burner switches
5. Fan burner and related air-pressure switch for fan-assisted appliance
6. Proflame 2 TMFSL\* Series Transmitter
7. Optional system elements: split flow control, comfort fan, dimmable lights and additional aux load, remote control adapter and/or local user interface (shown in Fig.3).

## INTRODUCTION

The Proflame2 IFC (Integrated Fireplace Control) board is a device that allows the automatic ignition and pilot flame supervision, to command the functions of an hearth appliance.

It is configured to control the ON/OFF main burner operation, giving the choice of both IPI (intermittent pilot ignition), and CPI (continuous pilot ignition - not available for 0584319) modes.

The Proflame2 IFC board controls directly the pilot assembly and an automatic valve 880, 886 and 885 of the Proflame families using low voltage electric power.

The IFC board is powered by Line voltage (AC) with provision of battery back up in case of main power loss. Fans and lighting features will not function when the IFC is powered by battery back up.

The Proflame IFC has the ability to control the comfort fan through 6 speeds, modulate an accent light through 6 levels and switch on or off an auxiliary output via the remote transmitter

Some product versions are equipped with a Pilot on Demand (PoD) software feature that shuts off the pilot flame after a period (normally 7 days) of continuous pilot operation without main burner heating request. In these versions, CPI mode is intended as "continuous pilot" for a limited time period.

## GENERAL CONNECTIONS

See Fig.1

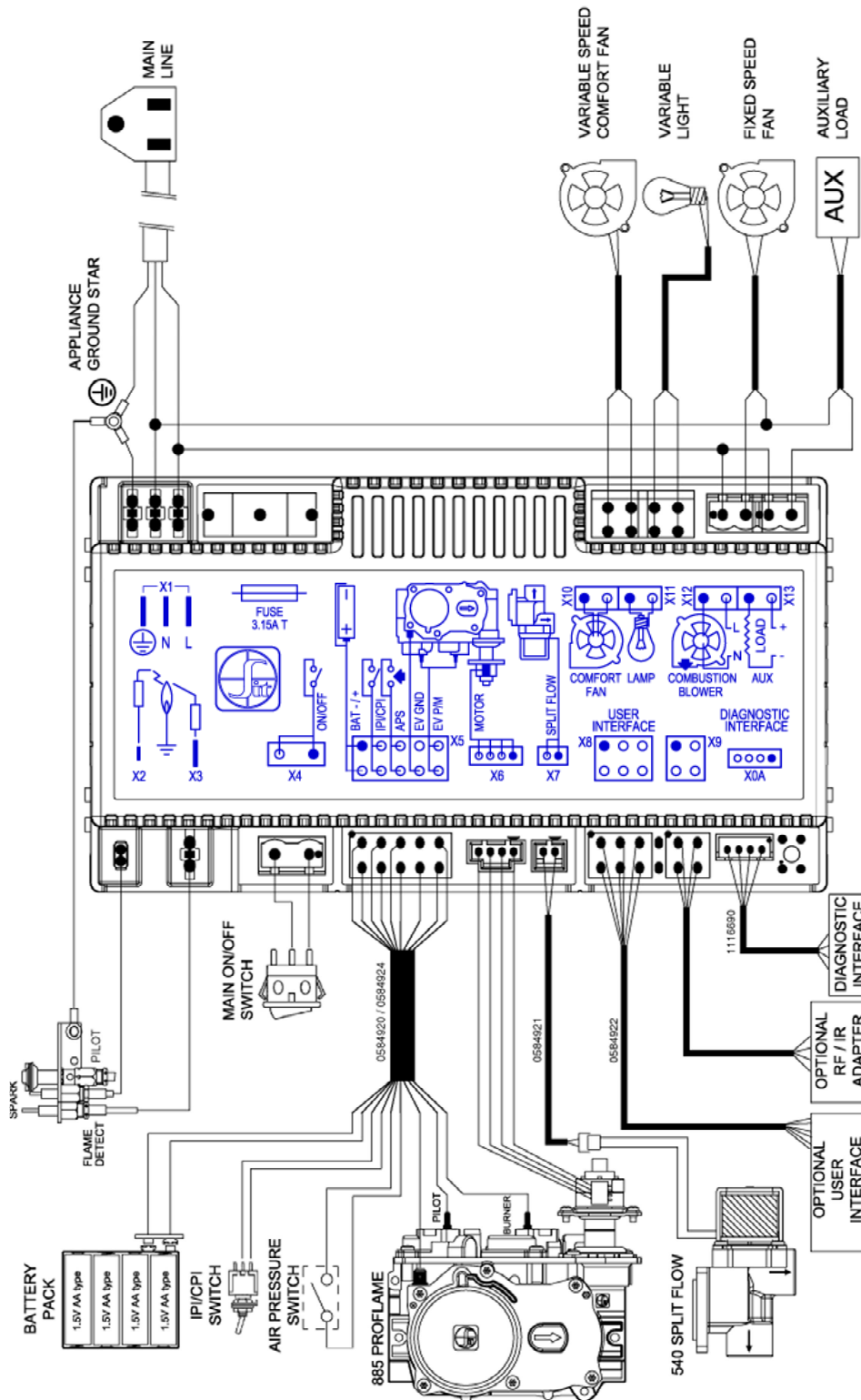

Fig.1

**MAIN TECHNICAL DATA**

AC supply voltage and frequency	110-240 V 50/60Hz max. 2.5A		
Battery supply voltage	6V		
Ambient Operating Temperature	-10÷80°C (-14÷176°F))		
Radio frequency remote control	433.92 MHz		
Light dimming output	110-240 V 50Hz(*) max. 0.5A (res.)		
Comfort fan output	110-240 V 50Hz(*) max. 2A (0.5pf)		
Burner fan output	110-240 V 50/60Hz max. 5A (0.5pf)		
Aux output	110-240 V 50/60Hz max. 5A (0.5pf)		
Spark voltage	>10kV over 5mm spark gap		
Spark energy	>0,7mJ		
Spark frequency	1Hz		
Pilot ignition source	Intermittent/Continuous		
Flame failure re-ignition time	0.8 s		
Waiting time	2 s		
Prepurge time	standard versions	ATMO	FAN
	0584319	2s	15s
Postpurge time	standard versions	ATMO	FAN
		2s	120s
Inter-ignition time	30 s		
Safety time	60 s		
Number of trial for ignition	2		
Comfort fan startup delay	standard versions	5 min	
	0584319	1 min	
Comfort fan shut off delay	standard versions	12 min	

(\*) 60 Hz or alternative configuration are depending by SIT product code.

Please refer both to "User and Installation manuals" of "Gas Valve" and "Pilot Assembly" for:

- the recommended gas input for the pilot burner
- the electrical specifications
- the operating temperatures and the components that have to be directly exposed to flame

## GENERAL CONNECTION & SET-UP GUIDE FOR PROFLAME 2 IFC BOARD

General connection and set-up guide for Proflame2 IFC board:

1. The IFC board should be placed in a low temperature area of the appliance.
2. Install the IFC in the appliance using screws.
3. Insert the 4 AA type batteries in the battery holder with the correct polarity.
4. Connect the switches.
5. Put the main switch in the "OFF" position (open) and the "IPI/CPI" switch on "IPI" position (open).
6. Connect the wiring harnesses to the loads.

## FUNCTIONS

### PRELIMINARY CHECK OF A PROFLAME2

Before applying any power supply to the IFC board please verify that the electrical connections are in accordance to Fig. 2, 3, 4 or 5.

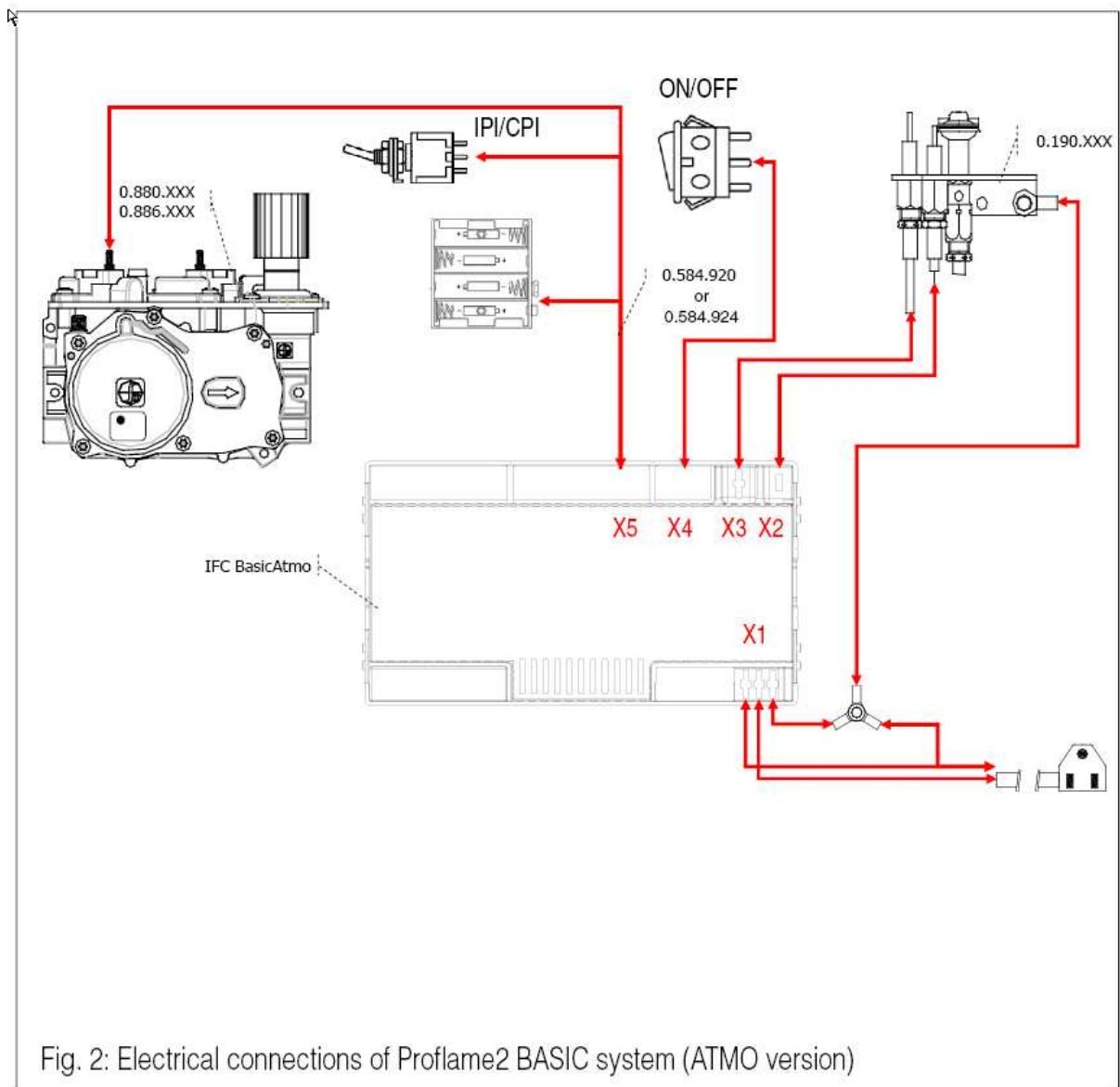

Fig. 2: Electrical connections of Proflame2 BASIC system (ATMO version)

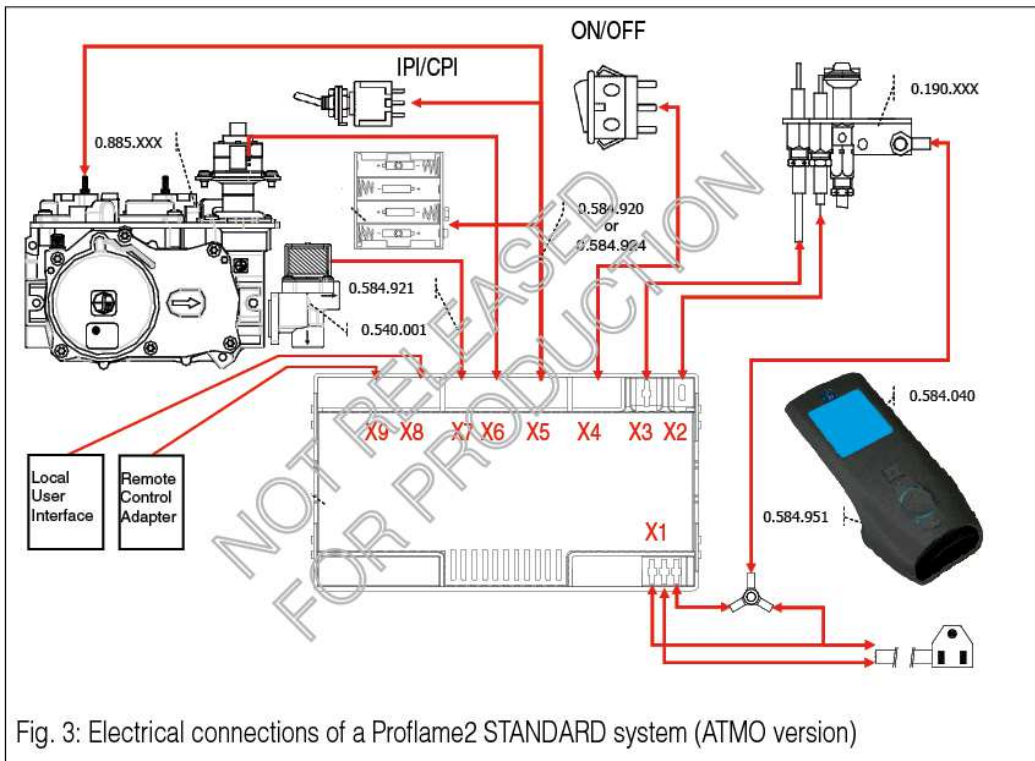

Fig. 3: Electrical connections of a Proflame2 STANDARD system (ATMO version)

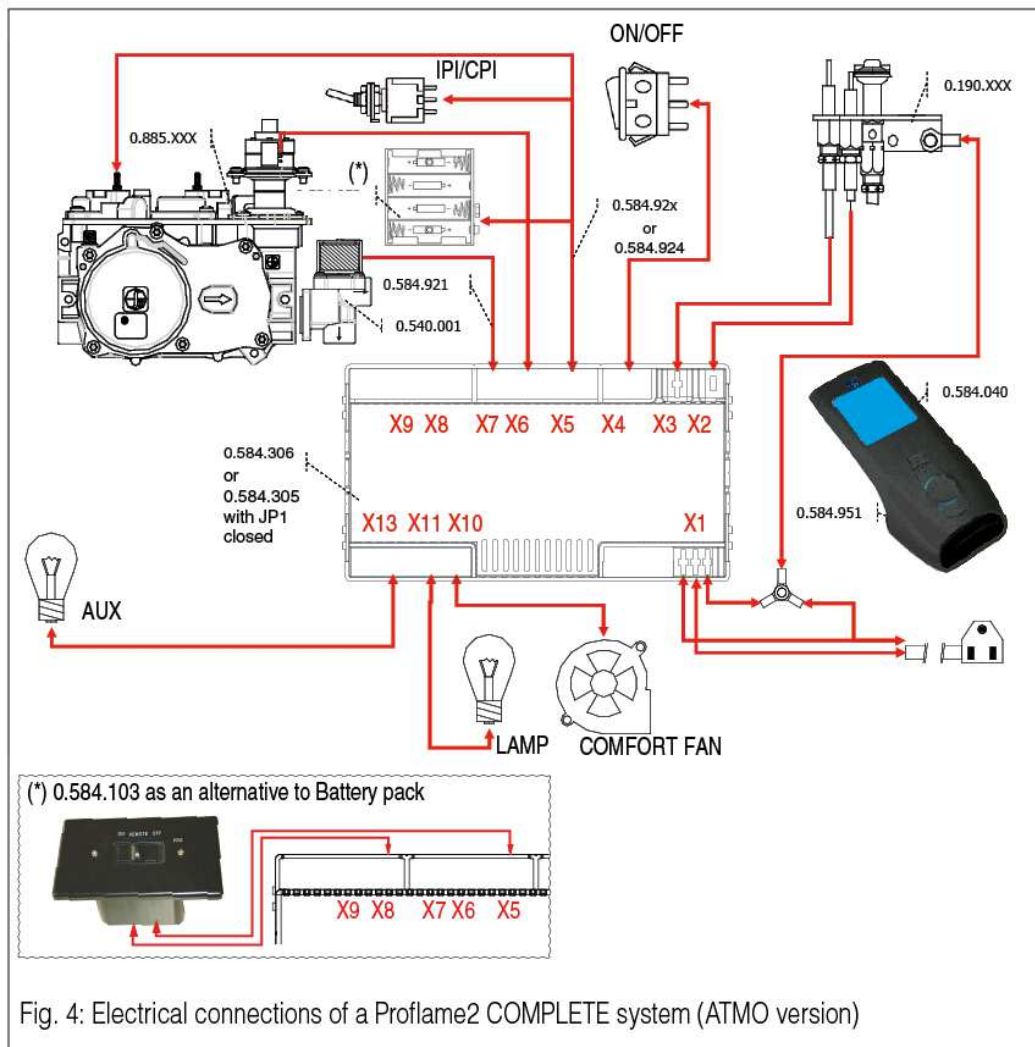

Fig. 4: Electrical connections of a Proflame2 COMPLETE system (ATMO version)



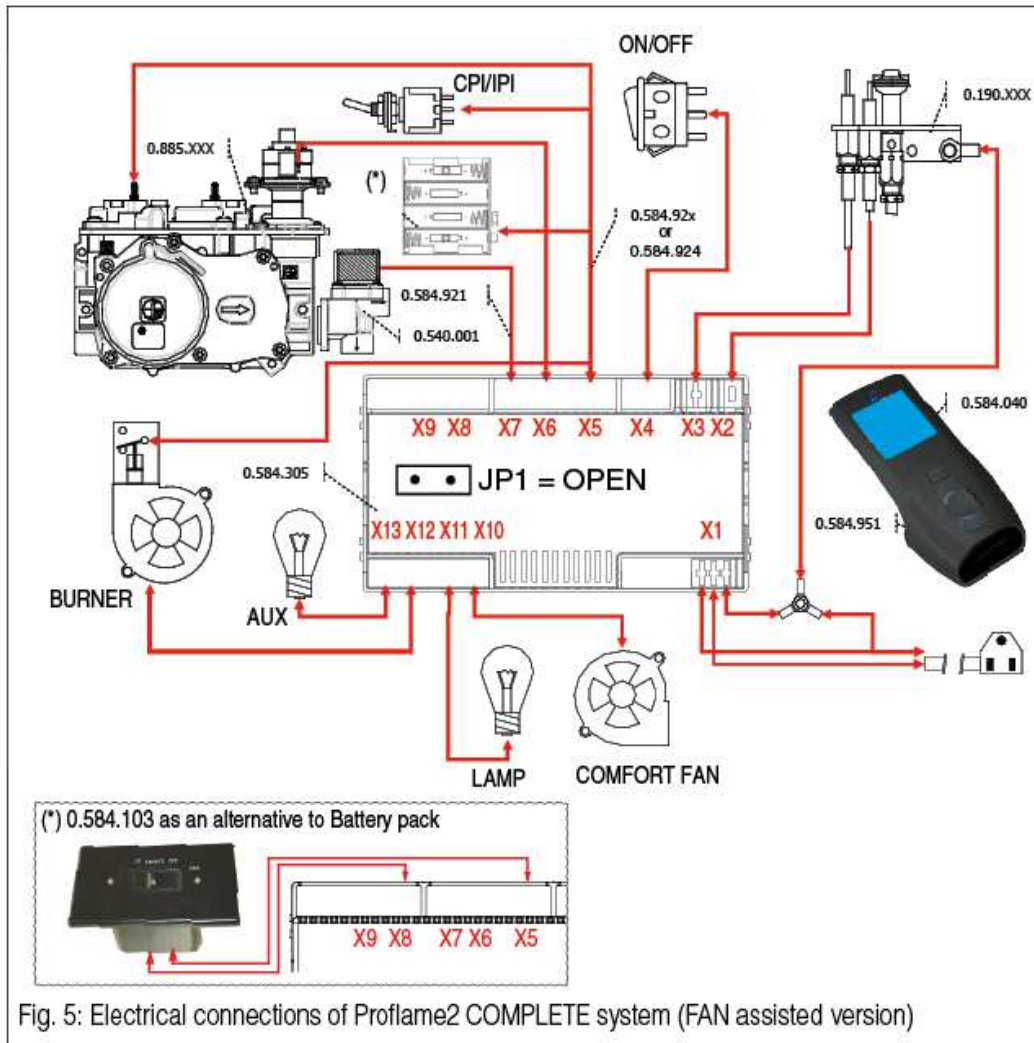
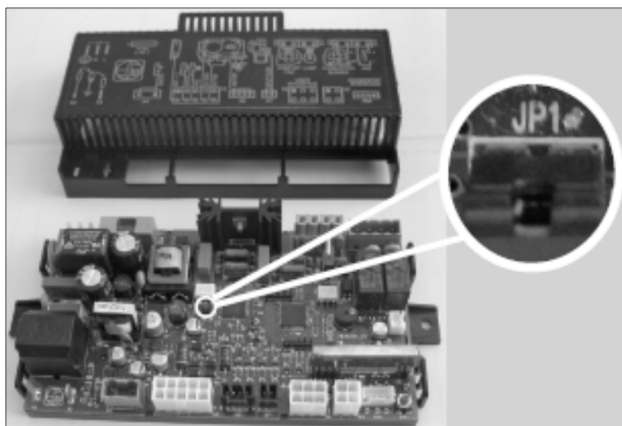



Fig. 5: Electrical connections of Proflame2 COMPLETE system (FAN assisted version)

### Initializing the System for the first time

Note : the models of IFC that can operate in either ATMO or FAN mode, are configured in the factory in ATMO mode ( Jumper JP1 closed). To enable the FAN mode, it is necessary to open the IFC removing the cover and then remove the jumper JP1 ( JP1 open), see Picture and Table below. 0584319 model is produced without inserting the JP1 jumper in order to be ready to operate in FAN mode.



JP1 STATUS	IFC board enabled mode
OPEN 	FAN
CLOSED 	ATMO (DEFAULT)

Follows the procedure below.

- Install the 4 AA batteries and select "REMOTE" slider position into the battery holder (if present). Install the 3 AAA type batteries in the battery bay, located in the base of the Transmitter. Note polarity of the batteries and insert them as indicated by silkscreen (+/-) in the battery cover/holder.
- Set the main burner flame "ON/OFF" command switch in "OFF" position.
- Set the main "ON/OFF" and the CPI/IPI switch in the closed position.
- Connect the AC power supply to the IFC.
- Press the SW1 button on the IFC module so the IFC will "beep" three (3) times and an amber LED is illuminated to indicate that the IFC is ready to synchronize with a transmitter within 10 seconds. With the batteries already installed in the Transmitter, push the ON button. The receiver will "beep" four times to indicate the transmitter's command is accepted.

The system is now initialized

### **Resetting the System for manual use**

Select "REMOTE" slider position into the battery holder (if present) and press the SW1 button on the IFC module so the IFC will "beep" three (3) times and an amber LED is illuminated to indicate that the IFC is ready to synchronize with a transmitter within 10 seconds. Press again SW1 button on the IFC module so the IFC will close synchronization without recording any remote control. In this condition no remote control is recognized and the user can manually operate pilot and main burner by way of "IPI/CPI" and "ON/OFF" switches.

### **Enable IPI/CPI mode**

In "BASIC" configuration, "CPI" mode is selected by closing the input "ON" in "X5".

In "STANDARD/COMPLETE" configuration, "CPI" mode is selected by remote control, but the "CPI" mode is enabled only if the input in "X5" is closed. In the case where the system has not been associated with any remote control, the "CPI" mode selection is enabled by closing the input in "X5". For 0584319 version the CPI mode is inhibited.

### **Enable burner flame**

In "BASIC" configuration, the burner flame is enabled by closing the input in "X4".

In "STANDARD/COMPLETE" configuration, the ON/OFF burner selection by remote control is enabled only if the contact of enable in "X5" is closed. In the case where the system has not been associated with any remote control, the "CPI" mode selection is enabled by closing the input in "X5".

### **Comfort Fan start up and shutdown timing**

The Comfort Fans is started with a delay of 5 minutes (1 for 0584319) from the fireplace ignition request and stopped with a delay of 12 minutes from the fireplace switch off.

Only for 0584319 version, the comfort fan level is superimposed to be the same of selected flame level.

### **Low battery power detection**

The life span of the receiver batteries depends on various factors: quality of the batteries used, the number of ignitions of the appliance, the number of changes to the room thermostat set point, etc. When the batteries are low a "double-beep" will be emitted from the IFC when it receives a command from the transmitter. This is an alert for a low battery condition of the receiver and after that no more command will be accepted. When the batteries are replaced the "beep" will be emitted from the receiver as soon as powered.



**STANDARD IDENTIFICATION:** EN 298, Automatic gas burner control systems for gas burners and gas burning appliances with or without fans.

**WARNING**

Fire Hazard. Can cause severe injury or death. The IFC device causes ignition of the appliance. The appliance can turn on suddenly. Keep away from the appliance burner when operating the remote system or activating manual bypass of the remote system.

**WARNING**

All the parts of the system are not intended to operate in presence of water dripping, spraying, rain, etc. that could generate also by condensation or ice that melts, etc.. Otherwise means shall be provided to protect all the components.

**WARNING**

Battery operated device. Read the battery instructions before installing them into the system. Do not expose any battery, or its holder, or a device in which batteries are installed, to a working temperature greater than 54°C / 129°F. Avoid battery overheating even if the working temperature of the device to which the batteries are connected is reported to be greater than 54°C / 129°F. In case of overheating the batteries will degrade their stored charge capacity, or leak corrosive liquids, or in bad cases, develop hydrogen gas and explode.

**CAUTION:**

Label all wires prior to disconnection when servicing controls. Wiring errors can cause improper and dangerous operation. Ensure that high voltage carrying wires (i.e. the spark igniter wire) are laid down far away (i.e. farther than 2,5cm – 1inch) from the electronic controlled devices.

**CAUTION**

Property Damage Hazard.



Excessive heat can cause property damage.

The appliance can stay lit for many hours.

Turn off the appliance if it is not going to be attended for any length of time.

**APPENDIX****1.Command definitions**

<b>Pilot IPI / CPI selector (*)</b>	<b>Main Turn ON selector (*)</b>	<b>Command reference name</b>	<b>Commanded Fireplace State</b>
Opened, IPI	Opened	Turn-OFF	Flames OFF
Opened, IPI	Closed	Turn-ON	Pilot + Main burner flames ON
Closed, CPI	Opened	Pilot-ON	Pilot flame ON
Closed, CPI	Closed	Turn-ON	Pilot + Main burner flames ON

(\*)In a "BASIC" configuration, the selectors are the switches connected to inputs "X4" and "X5". In "STANDARD / COMPLETE" configuration, the selectors are the result of the current status of the remote control in combination with the enable made by "X4" and "X5"

**2. IFC board operation****2.1 IPI operation mode**

The IPI operation mode means Intermittent Pilot Ignition. In this mode the CPI selector must be open. In this mode the board can be commanded to follow the ignition sequences for both the Pilot, and the Main Burner Flame as follows:

- starting from a completely shut OFF fireplace, with IPI Mode initially set,
- a Turn-ON command will initiate, and bring to completion the Pilot Flame ignition sequence, then the Main Burner Flame ignition sequence is automatically commanded after the Pilot Flame is detected steadily established,
- a Turn-OFF command will determine the gas valve shutdown so both the Pilot Flame, and the Main Flame will extinguish.

**2.2 CPI operation mode**

The CPI operation mode means Continuous Pilot Ignition. In this mode the CPI/IPI switch must be left closed. In this mode the board immediately completes the ignition sequence for the Pilot Flame, and then remains with the Pilot Flame ON, waiting for a command to ignite the Main Burner Flame as follows:

- starting from a completely shut OFF fireplace, with CPI Mode initially set,
- the Pilot Flame ignition sequence is initiated, and brought to completion, the Pilot ON state is maintained,
- a Turn-ON command will initiate the Main Burner Flame ignition sequence,
- a Pilot-ON command will shut down the Main Burner portion of the gas valve so the Main Flame will extinguish, leaving a permanent Pilot ON flame.

A Turn-OFF command is only possible by setting the IPI/CPI switch back to IPI position.

**2.3 Details about the ignition sequences for the Pilot Flame**

For the IFC board the Pilot flame is the supervised safety flame: it is used as the ignition flame source for the more powerful Main Burner Flame.

**2.3.1 Turn-OFF**

In this state, the gas to the appliance is cut-off by the gas valve. In this state the IFC board will wait for a command.

**2.3.2 Pilot-ON**

In this state the Pilot Flame sequence is executed, and it will lead the system to a continuous Pilot flame condition through these steps:

- if the previous state was Turn-OFF, the Pilot Flame detection is turned ON, a Pilot Flame check sequence is completed to avoid parasitic flame detection, the spark generator is activated, the Pilot gas valve solenoid is set to open the gas flow to the pilot hood, in the mean time the Main Burner gas valve solenoid is set to close the gas flow;
- if the previous state was Turn-ON, the Pilot Flame detection is maintained ON, the Pilot gas valve solenoid is set to keep opened the gas flow to the pilot hood, in the mean time the Main Burner gas valve sole is set to close the gas flow.

### **2.3.3 Turn-ON**

In this state both the Pilot, and the Main Burner Flames sequences are executed, and it will lead the system to a fireplace completely lit:

- if the previous state was Turn-OFF, the Pilot Flame detection is turned ON, a Pilot Flame check sequence is completed to avoid parasitic flame detection, the spark generator is activated, the Pilot gas valve solenoid is set to open the gas flow to the pilot hood, in the mean time the Main Burner gas valve solenoid is set to close the gas flow, the Pilot Flame is let to stabilize, the Main Burner gas valve solenoid is set to open the gas flow;
- if the previous state was Pilot-ON, the Pilot Flame detection is maintained ON, the Pilot gas valve solenoid is set to keep opened the gas flow to the pilot hood, in the mean time the Main Burner gas valve solenoid is set to open the gas flow.

### **2.3.4 Lockout state definition**

A lockout state is reached when an ignition error occurs, in any case the lockout on this board is volatile, this means that the lockout state will remain set in memory as long as the power supplies are applied.

This could mean both an anomalous flame detection, and/or too many unsuccessful ignition tries.

This state is a safe condition for the appliance, and is entered automatically by the IFC board.

When the IFC gets into lockout state:

1. both the Pilot, and the Main Burner solenoids in the gas valve are de-energized;
2. a diagnostic code is sent through the diagnostic red led.
3. the IFC board will ignore any burner ignition command, and remain in the OFF state, unless the unlock command sequence is met.

The causes of lockout must be investigated under safe conditions by the user and / or the service personnel.

To reset the IFC from a lockout state preform one of the following procedures:

- turning all the system power supplies OFF for a defined number of seconds, and then restoring a power supply back ON,
- a complete manual reset sequence: since the command reset sequence can be commanded through a remote receiver the lockout can be defined as Soft Lockout.

The return of the system to normal operation must be checked under safe conditions by the user and / or service personnel.

### 2.3.4.1 Lockout reset sequence

The command sequence to unlock the IFC board from the lockout state is the same whatever the command source is installed on the Main Turn ON command input.

When no remote is mated to the IFC:

- act on the Main Turn ON switch to put it into OFF position for at least 2s, then put it into ON position for at least 2s, then the IFC board will execute the internal tests and begin the ignition sequences.

Remotely commanded system:

- act ON/OFF slide switch: set it to OFF position for at least 2s, then set it to ON position for at least 2s, then the IFC board will execute the internal tests and begin the ignition sequences, or:

- act on the Proflame2 transmitter : turn OFF the flame request by the transmitter and wait in OFF state for at least 2s, then turn ON the flame request for at least 2s, then the IFC board will execute the internal tests and begin the ignition sequences: the proper acknowledgement of the transmitted OFF/ON commands should be heard through the feedback beep.

The IPI/CPI switch will not operate to unlock the board: it could be used anyway to test if a properly supplied IFC board is in lockout because setting the switch to CPI position, the IFC will not initiate the Pilot Flame ignition.

## 2.4 Diagnostics

The diagnostic signaling could be provided visually through the red led or through the diagnostic interface eventually installed in the system.

### 2.4.1 Real-time diagnostic messages – LED

The following diagnostic/alert signals could be interpreted in case of a system anomaly: obviously any indication is provided until a reliable level of power supply gets to the IFC board. The following codes appear in the reported order of priority:

RED LED SIGNALS					
Code	Lockout	Parasitic Flame	DFC power supply	Number of Flashes	Flashes Number
C3	Yes	Doesn't care	Enough power supply to signal	3	Some seconds
C2	No	Yes	Enough power supply to signal	2	
C1	No	No	Enough power supply to signal and the battery level is between the predefined minimum power supply range for the battery	1	
C0	No	No	Enough power supply for operation, battery voltage at reliable level or absent	none	

## 2.5 Special sequences: automatic safety restart

Whatever the IFC board state is in, it will execute automatically a Turn OFF command within 24 hours of continued pilot flame ignition. This command sequence will led the system to OFF state to verify the correct functioning of safety means. After the turn OFF sequence is completed, the board will re-execute the latest command.

### **3. IFC board behaviours under abnormal or particular conditions**

#### **3.1 A Pilot Flame is revealed before the Pilot Flame ignition sequence**

The system will not proceed to the gas ignition until a pilot flame is detected lit upon the start-up for the Pilot Flame ignition sequence.

#### **3.2 No pilot flame is established during the pilot ignition sequence**

If no pilot flame is sensed during the pilot flame ignition sequence, the system will retry for a predefined number of times. A waiting period is introduced between retries to purge the unburned gas from the appliance combustion chamber. After the last try with no successful ignition, the system will shut down the gas, and enter a VOLATILE LOCKOUT.

#### **3.3 Pilot loss of flame in Pilot-ON, or in Turn-ON states**

If a loss of the pilot flame signal is sensed during a state in which the pilot flame should remain lit, the system will proceed to restore the pilot flame ignition, and will close the main burner gas valve, and will start a timer to count the time from the flame failure.

If too many repeated pilot flame signal losses are detected within the timer expiration, the system will shut down the gas, and enter a VOLATILE LOCKOUT. If the pilot flame robustness timer elapses with the number of pilot flame losses within the predefined limit, the ignition sequence will continue normally.

When in Turn-On state, the main burner valve is open after 5 seconds from pilot flame detection, but, in case of 2 consecutive loss of flame with successful restoration, this delay is increased up to 1 minute.

#### **3.4 Behaviour of the IFC board in relation to the power supplies**

##### **3.4.1 Operation on dropout DC supply condition: the battery backup**

The battery supply is to provide back up power with limited functionality during a line power failure.

The IFC will continue operation in backup, without interruption, until the batteries are installed in the system and until the battery charge will be acceptable over the allowed minimum.

If the battery voltage drops below the minimum allowable voltage, the IFC may not be able to ignite the pilot and the system will shut down.

If a low battery level is detected, it will signal this anomaly through the diagnostic signalling device.

##### **3.4.2 Operation upon the restoration of the DC supply conditions, or replacement of the batteries**

If the AC line voltage is restored or the batteries are replaced with new ones, the IFC will ignite or maintain the pilot ON so the system will update its current status with the command selectors.

This means that if a thermostatic, or a manual switch is in closed position on the Turn-ON switch input, or the IPI/CPI switch is in CPI position, the IFC board will initiate the selected flame ignitions. This is due to the fact that the IFC board assumes the command switches state as an operational mode assertion principle, and is not able to distinguish a closed contact as closed intentionally, or automatically.