



SITGroup

## ACS II - LP



## AUTOMATIC CONTROL SYSTEM

### Field of application

Gas fired fireplace or logset

### Features

- Battery operated
- Remote ON/OFF control
- Remote setting of the flame height





The ACS is a gas control equipped with a microprocessor that provides all working sequences of the gas appliance. It is designed for gas appliances that use a gas pilot (including ODS) or at least a thermocouple placed on the burner. All safety requirements are demanded on the thermocouple. The valve is suitable for a heat input of up to 8 kW Natural Gas with 2.5 mbar of drop pressure.

## WORKING SEQUENCES

For a better understanding of the working sequences we can imagine the ACS with a Manual Control Panel. The working sequences are the same using other accessories.

- By pressing the first switch, this starts the ignition sequence (press & hold for 3 sec min). The gas to the pilot is open and the magnet unit pressed by the motor, the spark is generated. When the pilot flame presence is detected (ionization flame control) the system holds for 10 seconds to warm the thermocouple. When the thermocouple is able to hold the magnet unit the gas to the burner is open to maximum rate. In case of failure during pilot ignition, the EDB puts the system in safe mode. To restart the ignition sequence press the first switch.
- When the burner is working it is possible to have a pilot position only, press the 2<sup>nd</sup> switch. The appliance is now in stand-by mode and ready for main flame, press the 3<sup>rd</sup> switch.
- By pressing the 3<sup>rd</sup> switch the burner is light to the maximum rate and the input can be reduced (step-by-step) by press and hold the 4<sup>th</sup> switch. Vice versa for increasing the power, keeping pressed the 3<sup>rd</sup> switch, the power is increased

progressively.

- The OFF position is reached by pressing the 1<sup>st</sup> button.

All commands are accepted by the microprocessor when the push button is pressed for a few seconds. Anytime a button (of control panel or handset) is pressed, an audible "beep" will say that the signal has been received.

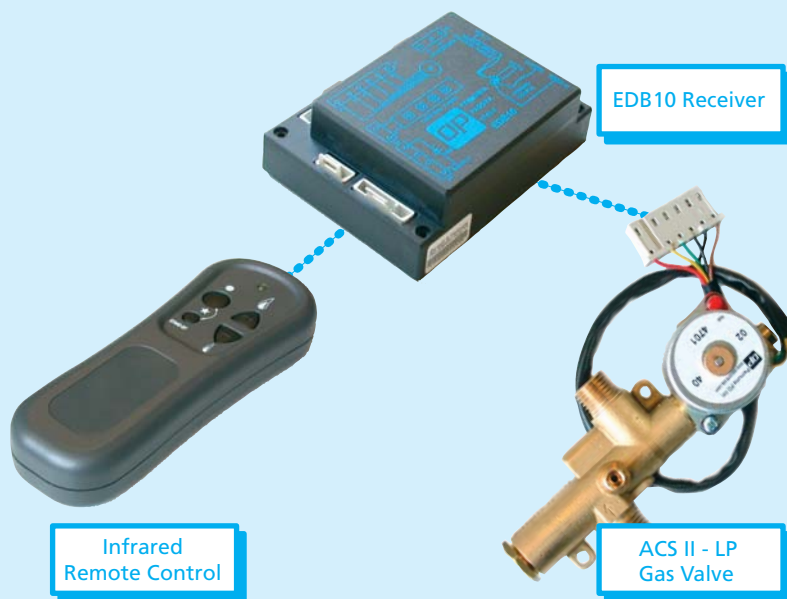

# ACS VALVE FULL MODULATION CONTROL

## TECHNICAL DATA

|                                      |                                    |
|--------------------------------------|------------------------------------|
| Maximum flow rate                    | 750 l/hr (air - 2.5 mbar)          |
| Minimum flow rate                    | Adjustable                         |
| Body temperature range               | 0 - 80 °C                          |
| Maximum working pressure             | 60 mbar                            |
| Magnet unit connection               | M8x1 or M9x1                       |
| Magnet unit drop out current         | > 80 mA                            |
| Magnet unit hold in current          | < 200 mA                           |
| Flame supervision device             | Class B (according to EN 125)      |
| Inlet and main outlet gas connection | M14x1.5 male                       |
| Inlet and main outlet pipe size      | Ø 8 mm                             |
| Gas families                         | I, II and III                      |
| Pilot gas connection                 | M8x1 male                          |
| Pilot pipe size                      | Ø 4 mm                             |
| Voltage supply                       | by Electr. Driv. Board type EDB 10 |
| Power consumption                    | 9 W (Peak)                         |
| Protection                           | IP 20 (with cover)                 |
| Working position                     | Multipoise                         |
| Torsion and bending resistance       | Group 1                            |

## DESCRIPTION

ACS Valve. Gas valve, the magnet unit and the relevant connection for the thermocouple; it has an inlet and 2 outlets: pilot and burner. The gas valve is equipped with a by-pass screw for adjusting the minimum flow rate. The electric motor provides a means of adjustment of the burner gas flow through step-by-step sequences.

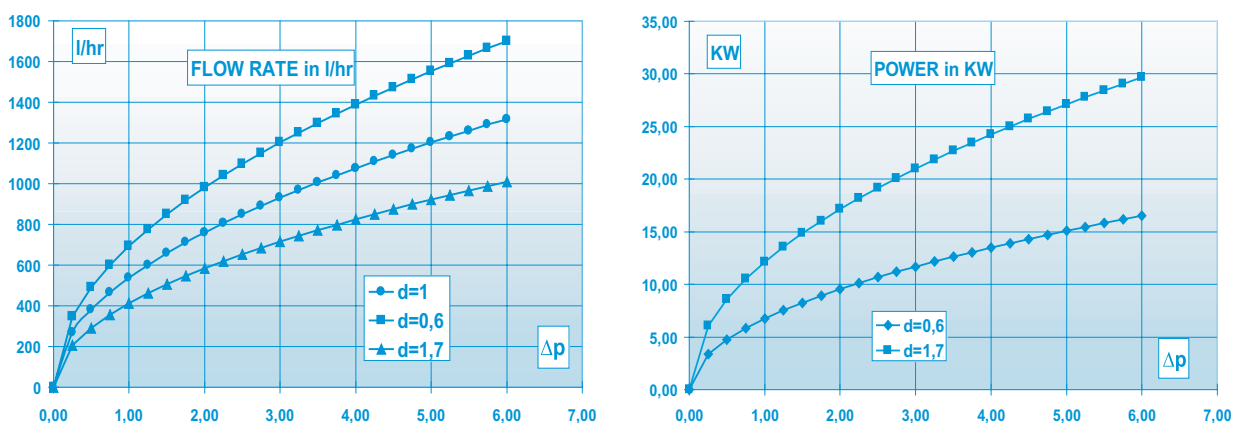
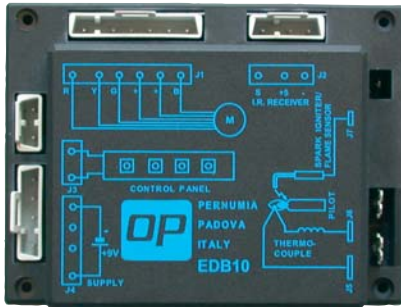

Fig. 1: ACS II - LP flow rate Q and power P as functions of pressure drop capacity.



# ELECTRONIC DRIVING BOARD



## DESCRIPTION

Electronic Driving Board (EDB). The EDB, fed by a battery pack (6x1.5 V battery type AA or equivalent), has a built-in microprocessor and an electronic igniter.

The thermocouple from the pilot is connected to the EDB. The EDB monitors for generated mill voltage (interruption), this allows for the off position.

## ELECTRONIC BOARD BATTERY SUPPLY OPTIONS

- 6 x size AA rechargeable batteries plus recharger (120 VAC or 230 VAC ).
- 6 x size C.
- 2 x size D batteries lithium type (dedicated).

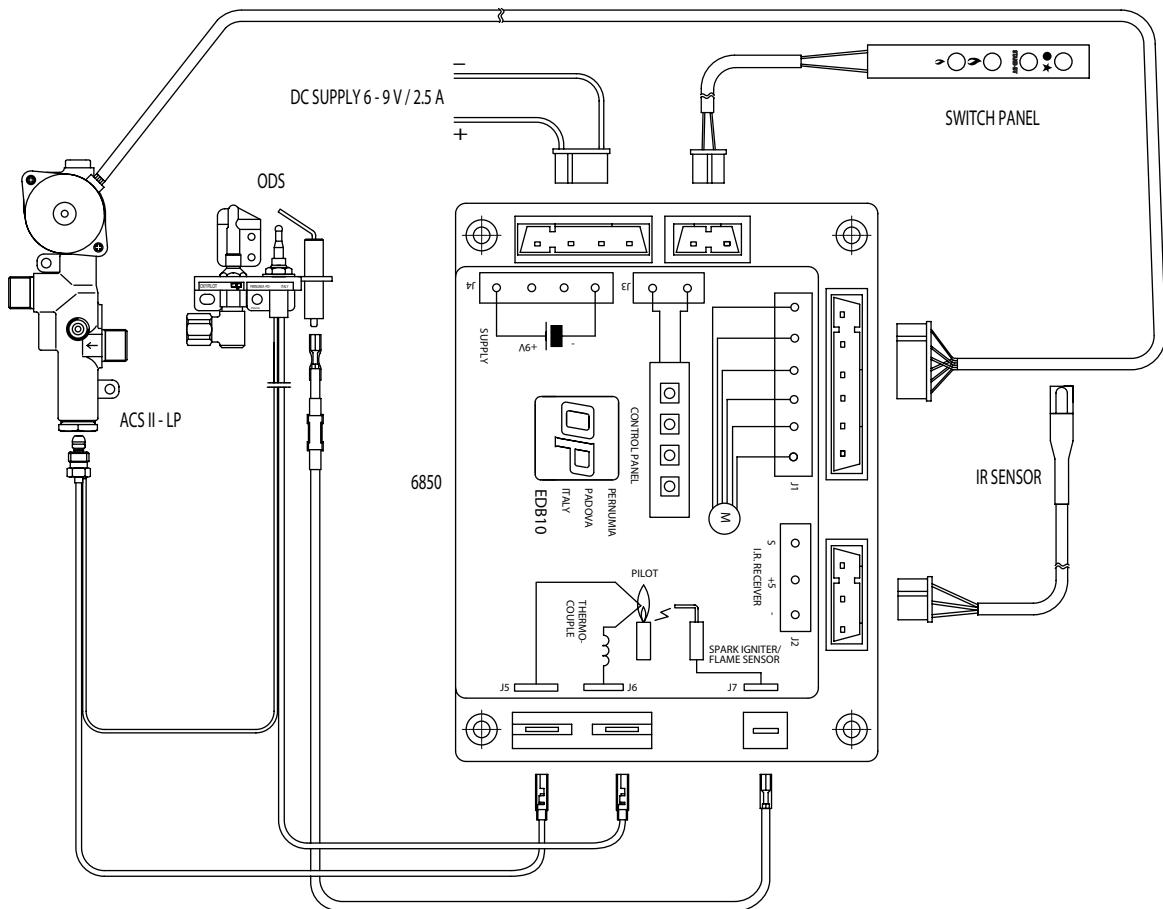

Fig. 2: ACS II - LP connection scheme. According DD ENV 1954:1997 Safety Class A.

## INSTALLATION

The Automatic Control System has to be installed in order to avoid excessive heat, humidity, dust, fat and oil. An excess of heat may damage the parts of the system and shorten the operational life. Temperature of battery size D (lithium type) never exceed 60°C. About other battery types follow customer indications. Furthermore it is convenient to use thermal screens when exposed to high temperature working conditions, as well as using the natural air draft of the appliance.

Installation on gas appliances should be verified to specific standards related to any particular gas appliance. It is recommended to not tamper with sealed parts and not remove any markings. Avoid any shock to the ACS. Do not exceed the advised mounting torques. Avoid the entrance of foreign parts into the device during assembly; in particular, verify the cleaning of gas pipes. To connect the device to gas pipes only use proper systems and tools, avoiding damaging of weak parts.

### CONNECTIONS

---

Connection of device gas inlet is via the appropriately designed connection. Gas soundness and strength must be achieved through metallic parts, avoiding sealing compound or rubber part. Pipe connection to the first outlet (pilot burner and/or first section of main burner) using a nut (M8x1) and olive of 4 mm diameter. Pipe connection to main outlet (main burner outlet) using a nut (M14x1.5) and olive of 8 mm diameter. Push fully down the pipes and tight with a max torque of 7 Nm, using a wrench holding the device in the proper location, do not stress the device during this operation. Connect the thermocouple terminal by tightening manually and then applying a quarter turn by using a proper size wrench: no gas soundness is required at this connection. Refrain excessive torque in order to avoid damage to the magnet Unit. Connect the electric motor using the correct fast-on terminals.

Connect the single parts of the system to the EDB using connectors and cable available, or replicate this connecting scheme when using your own connectors (STELVIO/ STOCKO). All cables and connectors should be suitable for a max working temperature of 90 °C. For ignition use only high voltage cables complying with EN60335-1: avoid the continuous contact of this cable with a metallic surface, to prevent possible reduction of spark voltage.

### ADJUSTING

---

Adjust the gas minimum rate by checking the minimum rate pressure to main burner through a pressure gauge or similar device.

### USAGE

---

The device is operated pressing the ON button on the control panel. Automatically the system starts the ignition sequence (duration about 10 sec). If there is sufficient power generated by the thermocouple the magnet unit becomes energized and the system will operate at max rate.

There is also the option to have the system in stand-by mode (pilot only). To change from MIN to MAX or MAX to MIN press the MIN or MAX button. The system is shut-off by pressing the OFF button. In the event of a power supply failure it is necessary to repeat the whole sequence of



ignition, as well as in case of safety shut-off.

All functions are achievable by remote control.

Filter available code: 4700-013.

The functions of the multifunctional control have been verified as being suitable for their application.

The control is according to EN 126 and it is designed for 10000 FSD operation cycles.

## MAINTENANCE

The system is not field serviceable. In case of malfunctioning substitute the failed component. Only authorized personnel can intervene on the complete system.

## ACCESSORIES

There are different options available to operate this system. The ACS is designed to work using these options in order to give flexibility to the manufacturer or end user. The options available are:

- Manual Control Panel, 4 switch panel, which will be self-adhesive and have a fixing point.

This can be mounted on the appliance (designed for trim mounting).

- Manual Wall Switch interface that allows use for fixed application (switch can be mounted on a wall).
- Thermostatic Interface (interface for using a standard mechanical thermostat).
- Remote Control Interface (kit for energizing the ACS using an infrared remote control. There are four switches on the hand piece as the standard switch panel).
- It is possible to convert one configuration to another but keep the same Electronic Driving Board.

### REMOTE CONTROL (with handset)

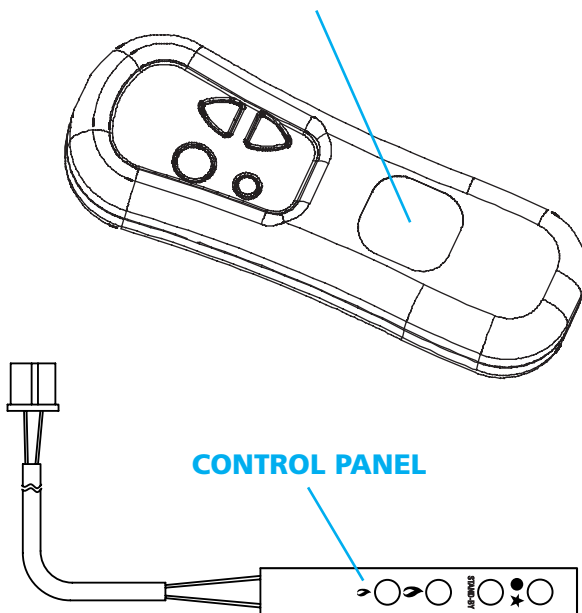
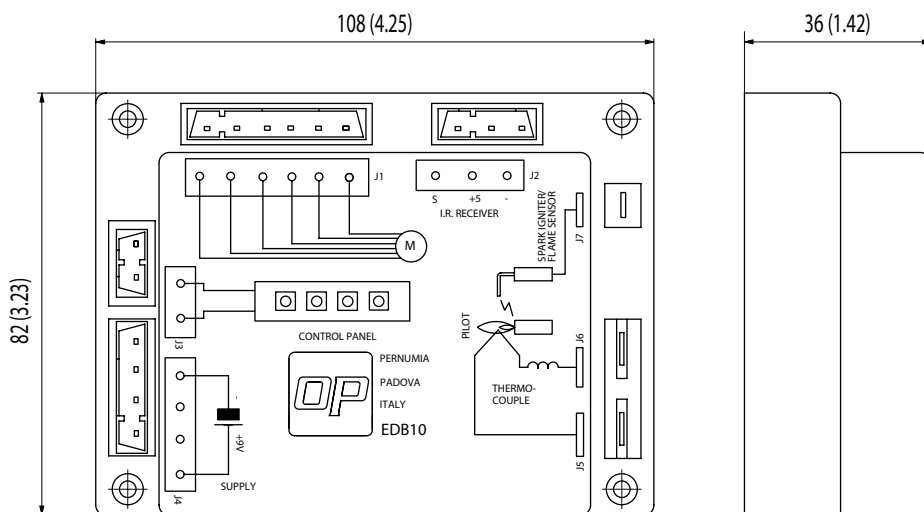
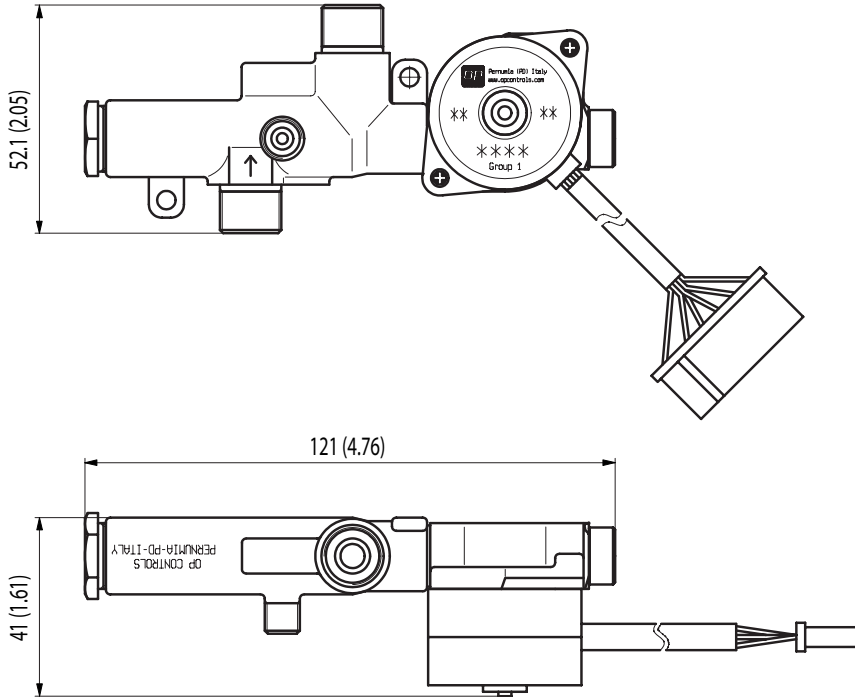

Fig. 3: ACS II - LP Accessories.

# DIMENSIONAL DRAWINGS



NOTE: All the dimensions are expressed in millimeters (inches).

**SITGroup**
**SIT La Precisa S.p.A.**

 Viale dell'Industria 31-33  
 35129 PADOVA - ITALY

 Tel. +39/049.829.31.11, Fax +39/049.807.00.93  
 www.sitgroup.it - e-mail: mkt@sitgroup.it

**Italy, Malta, Switzerland, West Slavic Republics,  
Spain, Portugal, Turkey**

 SIT La Precisa S.p.A., ITALY SALES AREA  
 Viale dell'Industria 32  
 35129 PADOVA - ITALY  
 Tel. +39/049.829.31.11, Fax +39/02.700.464.28  
 sit.italy@sitgroup.it

 LN2 Srl a socio unico  
 Via G. Deledda 10/12,  
 62010 Montecassiano (MC) - ITALY  
 Tel. +39/0733/591.411, Fax +39/0733/59.88.58  
 natalini@natalini.it

**France, Belgium, Maghreb**

 SIT FRANCE S.A.R.L.  
 13 Rue Raymond Losserand  
 75014 PARIS - FRANCE  
 Tel. +33/1/43.21.33.30, Fax +33/1/43.21.32.60  
 sit.france@sitgroup.it

**Germany**

 SIT CONTROLS Deutschland GmbH  
 Wiebelsheidestr. 45a  
 59757 Arnsberg - Germany  
 Tel. +49/2932/9694-0, Fax +49/2932/9694-50  
 sit.germany@sitgroup.it

**The Netherlands**

 SIT CONTROLS BV  
 A.G. Bellstraat 2 P.O. BOX 2088  
 7900 BB HOOGEVEEN - THE NETHERLANDS  
 Tel. +31/528/24.65.60, Fax +31/528/23.22.72  
 info@sitcontrols.nl

**United Kingdom**

 SIT - BRAY Ltd.  
 Education Road  
 LEEDS LS7 2AN - U.K.  
 Tel. +44/113/281.67.00, Fax +44/113/281.67.02  
 sit.uk@sitgroup.it

**North and Latin Americas**

 SIT CONTROLS U.S.A., Inc.  
 900 Center Park Drive, Suite J  
 Charlotte, NC 28217 - U.S.A.  
 Tel. +1(704)522.6325, Fax +1(704)522.7945  
 sit.usa@sitgroup.it

 SIT CONTROLS U.S.A., Inc.  
 2982 Old Laguardo Road 37087 LEBANON  
 TENNESSE - U.S.A.  
 Tel. +1/615/453/47/83, Fax +1/615/44.97.660  
 kdykassitusa@earthlink.net

 SIT CONTROLS U.S.A., Inc.  
 91 Oakcliff Drive. Laguna Niguel, CA 92677 - U.S.A.  
 Tel. +1/949/495.32.39, Fax +1/704/522.79.45  
 toleary@situsa.com

 SIT CONTROLS CANADA, Inc.  
 5511 Spruce Avenue  
 BURLINGTON ONTARIO - CANADA L7L 1P3  
 Tel. +1/905/637.74.56, Fax +1/905/637.40.07  
 pbsitusa@cogeco.ca

 SIT CONTROLS USA, Inc.  
 Ejército Nacional 708 - 1102, Col. Polanco  
 11560 MEXICO CITY D.F. - MEXICO  
 Tel. +52/55/52.03.04.04, Fax +52/55/52.54.77.69  
 vsztainbok@situsa.com

 SIT - MANUFACTURING NA  
 Avenida Texas 300, Parque Industrial Nacional  
 Cienega de Flores, N.L.  
 Mexico C.P.65550  
 Tel. +52 (81) 82210275, Fax +52(81) 83190626  
 antonio.elizondo@sitmna.com

 SIT CONTROL USA, South America Office  
 Rioja 656 Piso 11 "A"  
 2000 - Rosario (Pcia, Santa Fe) - ARGENTINA  
 Tel./Fax +54/341/447.05.93  
 gcabralrsit@ciudad.com.ar

**Australia, New Zealand**

 8 Pickering Road, Mulgrave  
 VICTORIA 3170 - AUSTRALIA  
 Tel. +61/3/95.60.14.44, Fax +61/3/95.60.01.95  
 sit.australia@sitgroup.it

**China**

 SIT GAS CONTROL SYSTEMS (SHANGHAI) Co., Ltd.  
 147 Chen An Road, MaLu Town Industrial Garden,  
 Jiading District  
 201801 SHANGHAI - CHINA  
 Tel. +86/21/59.10.29.28-59.10.05.63-59.10.15.77,  
 Fax +86/21/59.10.01.29  
 info@sitchina.com.cn

**Korea**

 SIT CONTROLS KOREA Co., Ltd.  
 Room N° 1412, Jamsil I-Space B/D 11-10,  
 Sincheon-dong, Songpa-Gu  
 SEOUL - KOREA  
 Tel +82/2/425.16.93-4, Fax +82/2/425.16.50  
 sitcontrols@korea.com

**Czech, Slovak Republics, Poland, CIS countries**

 SIT CONTROLS ČR, s.r.o.  
 Vídeňská 125  
 61900 BRNO - ČESKÁ REPUBLIKA  
 Tel. +420/5/47.12.53.53, Fax +420/5/47.12.53.55  
 sit.czechrep@sitgroup.it

**Russia**

 SIT Vostok OOO  
 Moscow - RUSSIA  
 Tel. +7/495/104.94.92  
 sit.vostok@sitgroup.it